

FORCE LABOUR AND CHILD LABOUR REPORT IN SUPPLY CHAINS



2023 Annual Report

About this Report: This Report was prepared by Kontron Canada Inc. pursuant to Canada's *Fighting Against Forced Labour and Child Labour in Supply Chains Act* (the "Report"). The Report was made for the financial year ended December 31, 2023 (the "Reporting Period"). This Report describes taken actions during the Reporting Period to prevent and reduce the risk that forced labour or child labour is used at any step of the production of the goods in the supply chain.

We recognize that risks of forced labour and child labour exist and acknowledge that understanding and managing these risks requires the collaboration of the suppliers, workforce and other external stakeholders.

1. OUR STRUCTURE, BUSINESS AND SUPPLY CHAIN

A. Corporate structure

Kontron Canada Inc. ("KCI") was created under the *Canada Business Corporations Act* on January 1, 2002. KCI is the sole company covered in this Report since KCI has no subsidiary. Our headquarters is in Boisbriand, Quebec. KCI is part of the Kontron AG ("Kontron Group") which comprises more than 44 entities in 23 countries and over 5,000 employees worldwide.



B. Activities

KCI designs, manufactures, and sells computer systems mainly in the telecommunications and avionic entertainment market. KCI serves customers worldwide but mainly in Europe and in the United States.

C. Supply Chain

KCI supply chain is a centralized function that supports our operations in Canada. KCI is working with multiple suppliers, agents and consultants around the world.

Here's our supply chain structure:

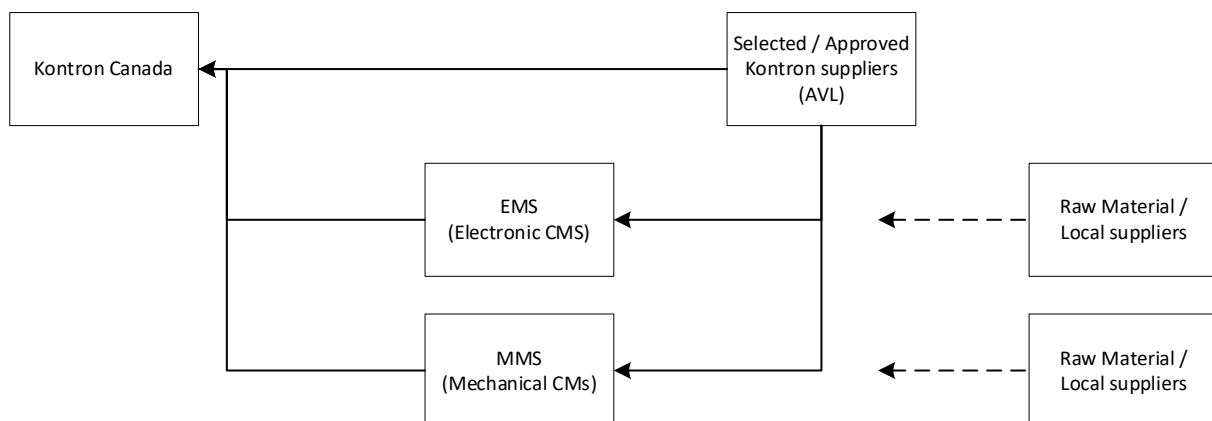

2. OUR POLICIES, DUE DILIGENCE PROCESSES AND ACTIONS

KCI and Kontron Group commitment to prevent forced labour and child labour in its business and supply chains are supported by appropriate policies and appropriate protections.

A. OUR POLICIES

i. Code of Conduct

KCI has a Code of Ethics that is applicable to all its employees that is based on the Kontron Group Code of Conduct with country-specific differences. The Code of Conduct establishes and reinforces the Kontron Group requirements and expectations of the group. The Code of Conduct applies to all employees, directors, and officers of the group. The Code of Conduct details the standard of behaviour expected from all employees. The Code of Conduct reiterates our position against the use of forced or child labour and contributes to ensuring that no forced or child labour is used in our supply chain. The Code of Conduct addresses other matters such as conflicts of interests, confidentiality, compliance with laws and reporting any illegal or unethical behaviour. The Code of Conduct and the KCI Code of Ethics are regularly reviewed.

ii. Supplier Code of Conduct

The Kontron Group Supplier Code of Conduct extends the principles of our Code of Conduct to our suppliers ("Supplier Code"). Our commitment to being socially, ethically, and environmentally responsible also extends to all our suppliers. The Supplier Code details our expectations of suppliers in regard Kontron the compliance with the laws and human rights, health and safety and all important behaviour expected from our suppliers. We require our suppliers to adhere to the Supplier Code when doing business with or on behalf of the Kontron Group. We expect suppliers to implement the Supplier Code and our requirements.

The Supplier Code explicitly includes:

"no forced or compulsory labor / slavery / human-trafficking / servitude

› no child labor (no workers under the age of 15/14 in accordance with ILO Conv. 138)

› no workers under the age of 18 for hazardous work...

Kontron does not tolerate child labor in any form and it s strictly prohibited and Kontron expects its suppliers to strictly comply also to this requirement. Moreover, its Kontron s expectation that supplier



also secures compliance in its own supply chain. Suppliers have to act in particular in accordance with the two fundamental ILO conventions on child labor (Convention No. 138 on Minimum Age and Convention No. 182 on the Worst Forms of Child Labor). Suppliers shall not employ anyone younger than 15 years of age, who is still of compulsory school age or who has not reached the legal minimum age for employment, whereby the regulation with the strictest age limit shall take precedence."

iii. Whistleblower Protections

All Code of Ethics, Code of Conduct or the Supplier Code have established whistleblower procedures. The personnel are required to report any actual or suspected violation of the law or of a policy. The whistleblower policy offers a variety of confidential reporting methods.



B. OUR DUE DILIGENCE PROCESSES AND ACTIONS TO ADDRESS THE RISKS

KCI is committed to combatting forced and child labour. We conduct due diligence assessments across the supply chain to identify, address and mitigate potential human rights issues. As part of the Kontron Group, we share common partners and suppliers, which strengthens Kontron's position with the partners and suppliers.

Here's a summary of the due diligence processes undertaken by KCI:

- Self assessment for each supplier: a questionnaire is used by KCI and needs to be completed by all supplier to ensure their compliance with labour and ethical standards.
- Standard Terms and conditions and supplier's contracts: Each standard terms and conditions and supplier's contracts include requirements for compliance with applicable laws and with the Kontron Group policies including the Supplier Code which prohibits the use of child labour, forced labour and modern slavery.
- Supplier Audits: KCI performed face-to-face audit at the Supplier's establishment based on the Supplier's risk.
- Supplier's evaluation: an evaluation is completed by KCI based on the Supplier's risk.
- Supplier Statement: Each supplier needs to sign a statement that they are compliant with all applicable laws and human rights.

3. EVALUATION AND MANAGEMENT OF THE RISK

A. [Our Risk Assessment](#)

Since KCI procures many goods and services from a broad range of industries both domestically and internationally and uses suppliers worldwide, we understand that there is a risk that forced and/or child labour may be used in our supply chain. We understand the importance of risk mitigation and we adopted some policies to manage the risks starting mainly with how we select our suppliers. The actions and due diligence processes mentioned in the Section 2 B. above help us to identify suppliers who comply with our requirements.

B. [Our remediation measures](#)

Since KCI processes did not identify any evidence of forced labour or child labour, KCI did not take or implement measures in the Reporting Period to remediate any forced or child labour nor to remediate any loss of income to vulnerable families that results from any measure taken to eliminate the use of forced labour or child labour in its activities and supply chains.

C. [Training](#)

As part of every new employee's onboarding program, a training is provided to review the KCI Code of Ethics. This training is also provided to all of the employees on a regular basis. Additionally, the Kontron Group provides training to all the employees regarding the Code of Conduct.

D. [Assessing our effectiveness](#)

KCI is dedicated to establishing a supply chain that protects human rights for all workers involved. Throughout 2023, our primary focus was to review our processes, policies and reinforcing them to effectively manage our suppliers and address critical issues related to forced labour and child labour.

While KCI believes that the processes and measures taken to prevent and mitigate forced labour and child labour within our operations and supply chain are effective, KCI will continue to identify, assess and mitigate our risks, while maintaining and improving these control processes KCI also intends to continue developing and implementing additional due diligence policies and processes for identifying, addressing, and prohibiting the use of forced labour and child labour in our activities and supply chain.



4. **REPORT APPROVAL AND ATTESTATION**

This Report was approved by KCI board of directors in accordance with section 11 of the Act. In accordance with the requirements of the Act, I, the undersigned, attest that I have reviewed the information contained in the Report for the entity specified below. Based on my knowledge, and having exercised reasonable diligence, I attest that the information in the Report is true, accurate and complete in all material respects for the purposes of the Act, for the Reporting Period.

I have the authority to bind Kontron Canada Inc.



Jason Larocque
President and CEO