

3.5"-SBC-AMH/ADH

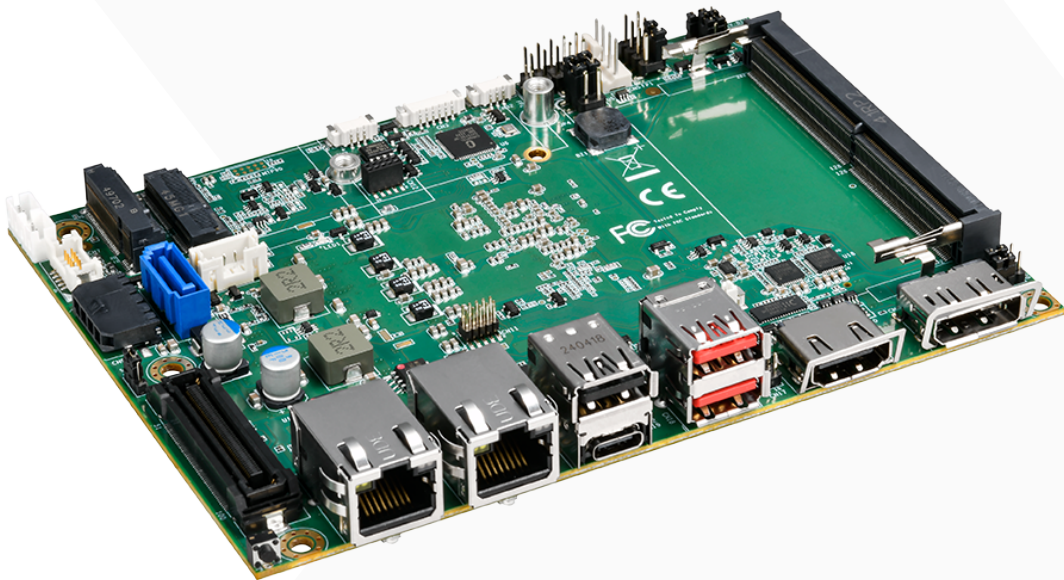

3.5" Single Board Computer with Intel® Atom® x7000(R)E Series, Intel® Core™ i3 N-Series & Intel® N-Series Processors

- A DisplayPort connector and a HDMI connector on rear I/O panel
- Upgraded processing and graphics performance + faster AI inference capability
- Time Coordinated Computing / Time Sensitive Networking for real-time communication
- Additional Rear I/O expansion via board-to-board connector
- DP Alt Mode over USB-C support to carry video / audio, data & power over a single port

3.5" Single Board Computer w/ Intel® Atom® x7000(R)E Series, Core™ i3 N-Series & Intel® N-Series

3.5"-SBC-AMH/ADH is a 3.5" single board computer powered by Intel® Atom® x7000RE Series (codenamed Amston Lake), Intel® Atom® x7000E Series, Intel® Core™ i3 N-Series and Intel® N-Series (codenamed Alder Lake N) processors integrated with Intel® UHD Graphics Gen12 as well as support for a next-gen high-speed DDR5 memory. Thus, it can deliver upgraded performance, enhanced

media transcoding and faster AI inference. Partial models support time sensitive networking (TSN) for real-time communication, making it an ideal baseboard to be integrated into a compact IoT edge system or an all-in-one solution for a variety of applications, such as smart retail, industrial automation, healthcare, video processing and office automation.

- Intel® Atom® x7000(R)E Series Processors
- Intel® Core™ i3 N-Series Processors
- Intel® N-Series Processors
- 1x DDR5 SO-DIMM memory socket
- 2x 2.5 GbE LAN for Ethernet
- 2x DP (1x full DP, 1x USB-C), 1x HDMI 2.0, 1x LVDS / eDP
- 3x USB 3.2 Gen 2 / Gen 1 (2x Type A, 1x Type C), 3x USB 2.0
- 4x RS232/422/485 for serial devices
- 4x DI, 4x DO for device / signal control
- 1x SATA 3.0 for storage device
- 1x M.2 Key B for SSD, WWAN or other possible expansion
- 1x M.2 Key E for WLAN, Bluetooth or other expansion

- 1x M.2 Key M for SSD
- 1x Board-to-board connector for additional rear I/Os
- TPM 2.0 support
- Extreme operating temperature range: -40 °C ~ 85 °C

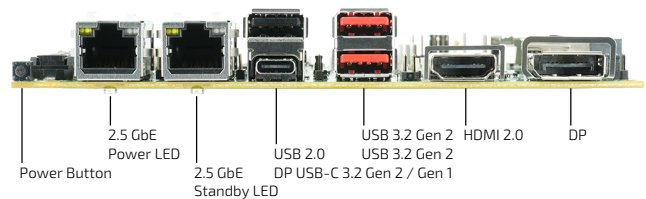

Block Diagram

Rear I/O Connector | Internal Connector

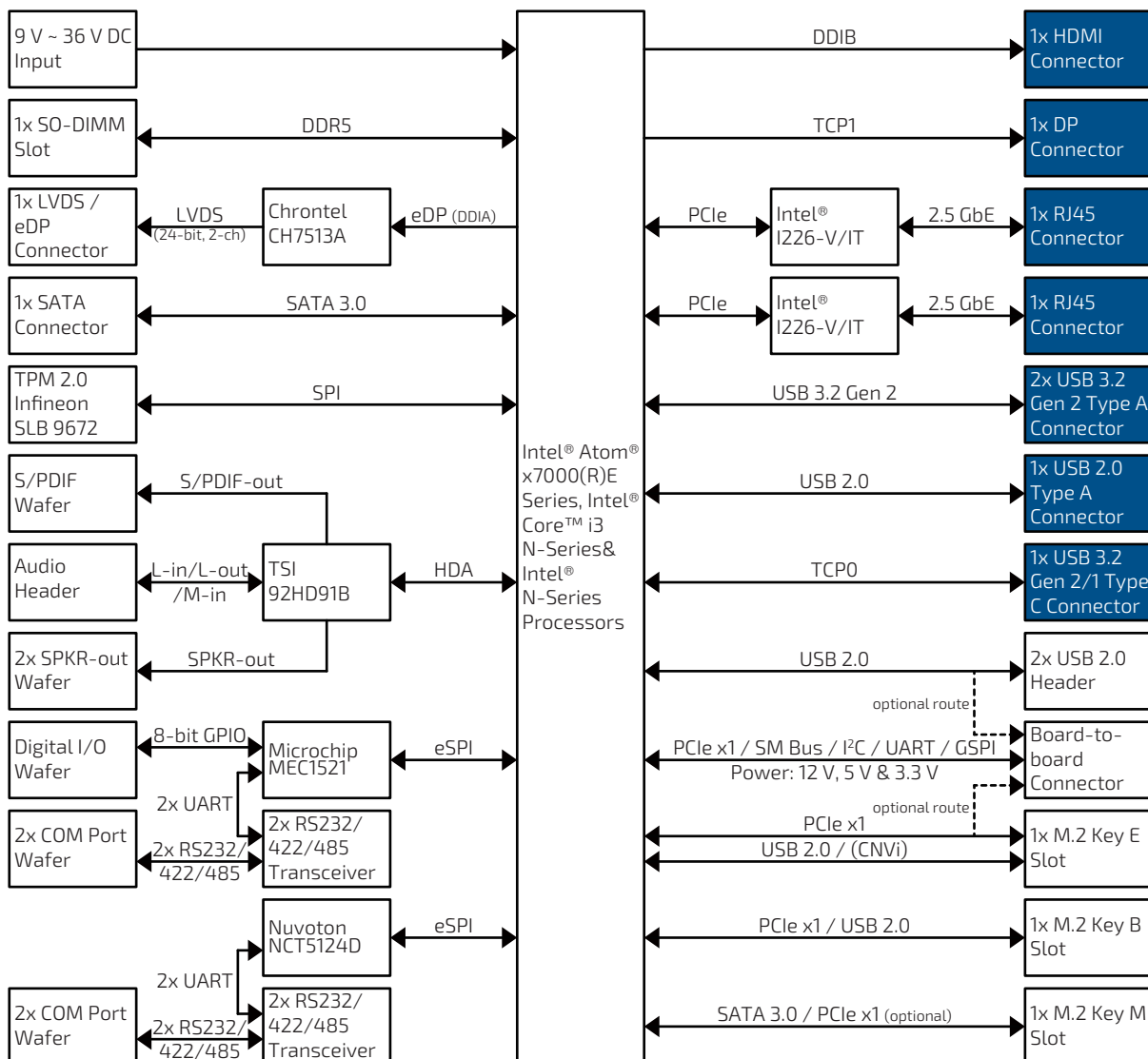

SYSTEM	PROCESSOR (STANDARD)	Intel® Atom® x7211RE (Dual Core, 6M Cache, 1.0 / 3.2 GHz, 6 W TDP) Intel® Atom® x7433RE (Quad Core, 6M Cache, 1.5 / 3.4 GHz, 9 W TDP) Intel® Core™ i3-N305 (Octa Core, 6M Cache, 1.8 / 3.8 GHz, 9 W ← 15 W TDP) Intel® N97 (Quad Core, 6M Cache, 2.0 / 3.6 GHz, 12 W TDP)
	PROCESSOR (PROJECT BASE)	Intel® Atom® x7213RE (Dual Core, 6M Cache, 2.0 / 3.4 GHz, 9 W TDP) Intel® Atom® x7835RE (Octa Core, 6M Cache, 1.3 / 3.6 GHz, 12 W TDP) Intel® Atom® x7211E (Dual Core, 6M Cache, 1.0 / 3.2 GHz, 6 W TDP) Intel® Atom® x7213E (Dual Core, 6M Cache, 1.7 / 3.2 GHz, 10 W TDP) Intel® Atom® x7425E (Quad Core, 6M Cache, 1.5 / 3.4 GHz, 12 W TDP) Intel® N50 (Dual Core, 6M Cache, 1.0 / 3.4 GHz, 6 W TDP) Intel® N200 (Quad Core, 6M Cache, 1.0 / 3.7 GHz, 6 W TDP)
	MEMORY	1x DDR5 4800 SO-DIMM up to 16 GByte
VIDEO	GRAPHICS DISPLAY INTERFACE	Intel® UHD Graphics Gen12 1x LVDS / eDP (24-bit, 2-ch, 1920 x 1200 @ 60 Hz / 4096 x 2160 @ 60 Hz) 2x DP (4096 x 2160 @ 60 Hz, 1x Full-size DP on rear, 1x DP USB-C on rear) 1x HDMI 2.0 (4096 x 2160 @ 60 Hz, on rear)
	MULTIPLE DISPLAY	Triple Display
AUDIO	AUDIO CODEC AUDIO INTERFACE	TSI 92HD91B 1x Speaker-out (Stereo, 3 W, by header) 1x Line-in (by header) 1x Line-out (by header) 1x Mic-in (by header) 1x S/PDIF Out (by header)
NETWORK CONNECTION	ETHERNET	2x 2.5 GbE LAN (RJ45 on rear, Intel® I226-V/IT, TSN support*)
PERIPHERAL CONNECTION	USB	2x USB 3.2 Gen 2 Type A (on rear) 1x USB 3.2 Gen 2 Type C (on rear, w/ DP & PD 5 V / 3 A, except Atom® x7000RE) 1x USB 3.2 Gen 1 Type C (on rear, w/ DP & PD 5 V / 3 A, only Atom® x7000RE) 3x USB 2.0 (1x Type A on rear, 2x by header (optl. routed to B2B connector))
	SERIAL PORT OTHER I/Os	4x RS232/422/485 (2x Tx/Rx only in RS232 signal, by header) 4x DI (by wafer) 4x DO (by wafer)
STORAGE & EXPANSION	SATA M.2	1x SATA 3.0 1x M.2 Key B (Type 2242 / 3042 / 3052 / 2280, w/ PCIe x1 / USB 2.0 / UIM) 1x M.2 Key E (Type 2230, w/ PCIe x1 (optl. routed to B2B) / USB 2.0 / CNVi**) 1x M.2 Key M (Type 2280, w/ SATA 3.0 (default) / PCIe x1 (optional))
	SIM CARD HOLDER BOARD-TO-BOARD CONNECTOR	1x SIM Card Holder (by header) 1x PCIe x1 (default) / 2x PCIe x1 (optional, 1x replacing PCIe in M.2 Key E) 1x SM Bus 1x I ² C 1x UART 1x GSPI 2x USB 2.0 (optional, replacing the route to 2x internal USB 2.0)
POWER	INPUT VOLTAGE CONNECTOR	DC 9 V ~ 36 V 1x4-pin pitch 3.0 mm Wafer
FIRMWARE	BIOS WATCHDOG H/W MONITOR REAL TIME CLOCK SECURITY	AMI uEFI BIOS w/ 256 Mb SPI Flash Programmable WDT to generate system reset event Voltages, Temperatures Processor integrated RTC TPM 2.0 Support (Infineon SLB 9672)
SYSTEM CONTROL & MONITORING	BUTTON, SWITCH & INDICATOR	1x Power Button (on rear) 1x Power LED (Green, on rear) 1x Standby LED (Yellow, on rear) 1x Internal Buzzer
	FP HEADER	1x Header for Reset Button, M.2 Key M LED & External Buzzer 1x Header for Power Button, Power LED & SM Bus 2x Header for 2.5 GbE LAN LED
COOLING	FAN	1x Wafer for Smart Fan
SOFTWARE	OS SUPPORT	Windows 11, Windows 10, Linux
MECHANICAL	DIMENSION (L x W)	ECX (146 mm x 105 mm / 5.75" x 4.13")
ENVIRONMENTAL	OPERATING TEMPERATURE	0 °C ~ 60 °C / 32 °F ~ 140 °F (Standard) -40 °C ~ 85 °C / -40 °F ~ 185 °F (Extreme)
	STORAGE TEMPERATURE	-20 °C ~ 80 °C / -4 °F ~ 176 °F (Standard) -55 °C ~ 85 °C / -67 °F ~ 185 °F (Extreme)
	HUMIDITY	0 % ~ 95 %
COMPLIANCE	EMC SAFETY	CE, FCC, ICES, UKCA (level class TBD) UR (UL Recognized TBD)

* TSN support for models with Atom® processors

** Atom® x7000RE Series processors do not support CNVi

Ordering Information

ARTICLE	ORDERING CODE*		DESCRIPTION
	EMEA / AMERICA	APAC	
3.5"-SBC-AMH-0-x7211RE-XT	TBD		Intel® Atom® x7211RE, Intel® I226-IT, Operating Temperature: -40 °C ~ 85 °C
3.5"-SBC-AMH-1-x7433RE-XT	TBD		Intel® Atom® x7433RE, Intel® I226-IT, Operating Temperature: -40 °C ~ 85 °C
3.5"-SBC-ADH-0-N97	TBD		Intel® N97, Intel® I226-V, Operating Temperature: 0 °C ~ 60 °C
3.5"-SBC-ADH-1-i3-N305	TBD		Intel® Core™ i3-N305, Intel® I226-V, Operating Temperature: 0 °C ~ 60 °C

* For ordering code for APAC, contact your local account manager.
(Contact your account manager for other processor variants or other operating temperature ranges.)

Accessories

NO.	ARTICLE	ORDERING CODE		DESCRIPTION
		EMEA / AMERICA	APAC	
1	DC IN CABLE*	1064-2433	0C502000004220L	2.5 mm DC Jack to H-300F-XX 1x4P 3.0 mm pitch, L = 300 mm
2	SATA CABLE	1064-2431	0C502000004240L	1x7p connector with lock, pitch = 1.27 mm, L = 460 mm
3	SATA POWER CABLE	1064-2430	0C502000004230L	1x4P 2.0 mm pitch to SATA 1x15P 1.27 mm pitch, L = 460 mm
4	COM PORT CABLE	1064-2427	0C502000005130L	1x10P 1.25 mm pitch to DB9 connector, L = 350 mm
5	DIO CABLE	1065-3137	0C502000003360L	D-SUB-9P (Female) to MX51021-10P 1x10P 1.25 mm pitch, L = 200 mm
6	USB CABLE (2 PORT)	1069-7893	0C5020003000010L	2x5P 2.0 mm pitch to 2x USB 2.0 Type A female w/ bracket, L = 27 cm
7	AUDIO CABLE	1070-1245	0C502000005840L	2x5P 1.25 mm pitch to 3x 3.5 mm ear phone jack, L = 400 mm
8	ADAPTER	1069-3055	0I0902G5T60A101L	Input: AC 90 V ~ 264 V, output: DC 12 V @ 5 A Max. 60 W
9	SCREW COPPER PILLAR KIT	TBD	0ZHK35SBC0000001	4x 39.6 mm pillar, 3x 19 mm pillar, 4x 15 mm screw, 1x 5 mm screw
10	HEATSINK	1070-1238	0ZHK35SEKL000001	Aluminum heatsink w/ thermal pad & 2x screw
11	I/O CARD (3.5"-elO-GPA-0)	1069-6159	B35EGPA0-001001T	2x DP, 2x 2.5 GbE, 1x UART, 1x I ² C, 1x SMBus, 1x GSPI, 1x DC In, 0 ~ 60 °C
12	I/O CARD (3.5"-elO-GPA-1)	1069-6922	B35EGPA0-011001T	2x DP, 2x 2.5 GbE, 1x UART, 1x I ² C, 1x SMBus, 1x GSPI, 0 ~ 60 °C
13	I/O CARD (3.5"-elO-GPA-2-XT)	1073-9682	B35EGPAI-021000T	2x DP, 2x 2.5 GbE, 1x UART, 1x I ² C, 1x SMBus, 1x GSPI, 1x DC In, -40~85°C

(*: standard supplied accessories for single-piece box packing)

Starter Kits

ARTICLE	ORDERING CODE		DESCRIPTION
	EMEA / AMERICA	APAC	
STARTER KIT FOR 3.5"-SBC-AMH/ADH	1070-4932	0ZHK35SEKL000003	Including above accessories table No. 1 ~ 10

Global Headquarters

Kontron Europe GmbH

Gutenbergstraße 2
85737 Ismaning, Germany
Tel.: + 49 821 4086-0
info@kontron.com

www.kontron.com